

CHRYSSAFIDIS

**ELECTRIC POWER**

	<b>Mod. J3C L-20</b>	<b>Mod. J3C H-20</b>
<b>VOLTAJE /VOLTAGE</b>	12 a 24 VAC/VDC -0/+5%	85 to 240 VAC/VDC
<b>TIEMPO MANIOBRA EN VACÍO</b>	10 seg.	10 seg.
<b>OPERATION TIME UNLOAD</b>	10 sec	10 sec
<b>PAR MÁXIMO ARRANQUE</b>	25 Nm	25 Nm
<b>MAXIMUM TORQUE BREAK</b>	221 lb/in	221 lb/in
<b>PAR MANIOBRA EN OPERACIÓN</b>	20 Nm	20 Nm
<b>MAXIMUM OPERATIONAL TORQUE</b>	177 lb/in	177 lb/in
<b>TIEMPO BAJO TENSIÓN %</b>	75%	75%
<b>DUTY RATING %</b>	75%	75%
<b>ÁNGULO MANIOBRA</b>	90° a 270°	90° a 270°
<b>WORKING ANGLE</b>	90° to 270°	90° to 270°
<b>INTERRUPTOR FINAL DE CARRERA</b>	4 SPDT micro	4 SPDT micro
<b>LIMIT SWITCH</b>	4 SPDT micro	4 SPDT micro
<b>RESISTENCIA CALEFACTORA</b>	3,5 W	3,5 W
<b>HEATER</b>	3,5 W	3,5 W
<b>CONECTORES</b>	DIN 43650	DIN 43650
<b>PLUGS</b>	ISO440 & C192	ISO440 & C192
<b>PROTECCIÓN IEC 60529 /IP RATING</b>	IP-67	IP-67
<b>TEMPERATURA /TEMPERATURE</b>	-20°C +70°C	-20°C +70°C
<b>CONSUMO A PAR MÁXIMO +/-5%</b>	24 VAC 787,5 mA - 18,9 W 24 VDC 913,5 mA - 21,9 W	110 VAC 168 mA - 18,5 W 220 VAC 84 mA - 18,5 W
<b>CONSUMPTION AT MAXIMUM TORQUE +/-5%</b>	24 VAC 787,5 mA - 18,9 W 24 VDC 913,5 mA - 21,9 W	110 VAC 168 mA - 18,5 W 220 VAC 84 mA - 18,5 W

**OPCIONES TODOS LOS MODELOS:**

- Kit posicionador digital DPS2005: 0 ÷ 20 mA, 4 ÷ 20 mA o 0 ÷ 10 V
- Kit potenciómetro digital: 1K, 5K y 10K
- Kit BSR retorno por batería
- 3 posiciones: 0°-45°-90° / 0°-90°-180°
- Salida: \*9, \*11 y \*14
- SÓLO J3C 20 y J3C 35: Kit conversión de F05 a F07

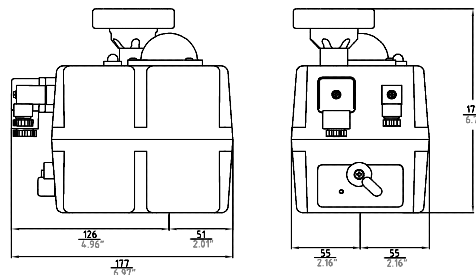

**ALL MODELS OPTIONS:**

- DPS2005 digital positioner: 0 ÷ 20 mA, 4 ÷ 20 mA o 0 ÷ 10 V
- Digital potentiometer kit: 1K, 5K and 10K
- BSR battery fail safe kit
- 3 positions: 0°-45°-90° / 0°-90°-180°
- Output : \*9, \*11 and \*14
- J3C 20 & J3C 35 ONLY: Conversion kit from F05 to F07

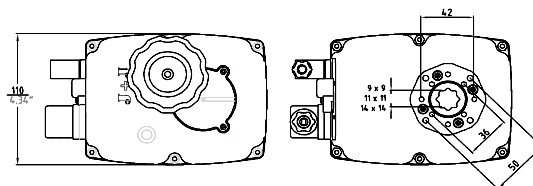

**CARACTERÍSTICAS GENERALES:**

- Envolvente (Cuerpo y tapa): Poliamida anticorrosiva
- Ejes principales: Acero Inox
- Tornillería exterior: Acero Inox
- Engranajes: Acero y Poliamida
- Indicador visual posición poliamida+ fibra vidrio
- Levas internas: Poliamida + fibra vidrio
- Motor Monofásico: 24 VDC
- Aislamiento B
- Servicio S4
- Tiempo bajo tensión 75%

**TECHNICAL DATA:**

- Housing (Body and Cover): Anticorrosive Polyamide
- Main external shaft: Stainless Steel
- Fastening : Stainless Steel
- Gears: Steel and Polyamide
- Indicator: Polyamide + Glass filled
- Internal cams: Polyamide + Glass filled
- Electric motor: Single phase
- Insulation: Class B
- Service S4
- Duty range: 75%



**CHRYSSAFIDIS**

# J3C series

**J3C** multivoltage reversible electric actuators

**J3C** is the new concept ¼ turn multivoltage electric actuator that finally offers all the solutions that utilize the reversibles electric actuators for the operation and control of the valves.

**J+J** following as always our politics of improvement and incorporation of the new products in the valve automation market we have obtained a product where operation security, economy in cost and releases life has been the principal objective.

ALL **J3C** TYPES AND MODELS have the following STANDARD features:

**ATC AUTOMATIC TEMPERATURE CONTROL:**

An internal 4 W thermostatically controlled anticondensation heater maintains the internals between: +20°C and +30°C, (68°F – 86°F) eliminating the possibility of damage by condensation.

**AVS AUTOVOLTAGE SENSING:**

The **J3C** actuators are, within the voltages ranges specified for "L" or "H" series, multi-voltage capable and make automatic internal adjustments to ensure the actuator operates, irrespective of the power supply  
"L" series operates from 12 to 24 VAC or 12 to 24 V DC  
"H" series operates from 85 to 250 VAC or DC

**ETL ELECTRONIC TORQUE LIMITER:**

Continuous electric monitoring of the motor produces smooth operation and accurate control of the motor consumption up to the maximum permissible torque. Should the maximum torque be exceeded, the ETL automatically cuts the power to the motor to prevent damage to the actuator, and automatically relaxes the gearbox to allow simple operation of the manual override.

**MO MANUAL OVERRIDE:**

For emergency manual operation, operated by a selector lever on the side of the actuator, with automatic motor power tripping when selected.

**PES PROTECTED ELECTRICAL SUPPLY:**

The J3 accepts the same wiring connection for either AC or DC operation (grey connector)  
External DIN plugs eliminate the need to remove the actuator's cover to connect.

**VCO VISUAL CONTROL OF OPERATION:** A constantly lid of the external LED indicates the normal operation of the actuator.

- A flashing LED frequency 1 advises that the actuator's torque limiter has been exceeded and the ETL has activated.
- A flashing LED frequency 2 advises that the actuator is in MANUAL position.

**VFC VOLT FREE CONTACTS:**

1 set of open and closed volt free contacts are provided.

Actuador eléctrico reversible multivoltage **J3C**

**J3C** es el nuevo concepto de actuador eléctrico multivoltaje rotativo ¼ vuelta que definitivamente ofrece todas las soluciones que precisan los modernos sistemas de proceso que utilizan actuadores eléctricos reversibles para el accionamiento y control de válvulas de bola, mariposa, grifos de macho, "dumpers", etc.

En **J+J** siguiendo, como siempre, nuestros objetivos hemos conseguido un producto donde la seguridad de funcionamiento, economía en costo y larga vida han sido cuidados hasta el más mínimo detalle.

TODOS LOS MODELOS **J3C** series "L" y "H" incorporan el siguiente equipo

**ATC CONTROL TÉRMICO DE LA TEMPERATURA:**  
Calefactor de 4 W controlado termostáticamente para el mantenimiento de la temperatura interior entre 20° y 30°C (68° F – 86° F) y evitar así daños por condensación.

**AVS MULTIVOLTAJE:**

Alimentación eléctrica corriente alterna o continua indistintamente:  
Serie "L" : de 12 a 24 VAC o 12 a 24 VDC  
Serie "H" : de 85 a 250 VAC o DC

**ETL CONTROL ELECTRÓNICO DE PAR:**

El continuo control electrónico produce un funcionamiento suave así como un cuidadoso control del consumo del motor hasta el máximo par permitido. Cuando éste es excedido, el sistema ETL suspende la alimentación eléctrica para prevenir posibles daños al actuador y libera la presión de los engranajes para facilitar el accionamiento del mando manual de emergencia.

**MO MANDO MANUAL DE EMERGENCIA:**

Situando la palanca en posición manual el motor queda automáticamente desconectado del tren de engranajes y puede accionarse manualmente la válvula.

**PES CONFIGURACIÓN CONEXIÓN AC / DC:**

Ambas opciones son posibles para el mismo actuador simplemente debe conectarse la alimentación eléctrica (conector color gris) según el esquema de conexiones que figura en la etiqueta exterior del actuador.  
Conectores externos DIN facilitan la conexión eléctrica al actuador sin necesidad de abrir la tapa del mismo.

**VCO CONTROL VISUAL DE OPERACIÓN:**

Un LED externo constantemente iluminado nos indica el normal funcionamiento del actuador.  
- LED externo destellante frecuencia 1 indica que el máximo par permitido ha sido sobrepasado.  
- LED externo destellante frecuencia 2 indica que el actuador está en posición "manual".

**VFC CONTACTOS AUXILIARES:**

2 contactos (micro interruptores) adicionales para transmisión de señal. Ej. : Señalización de posición.



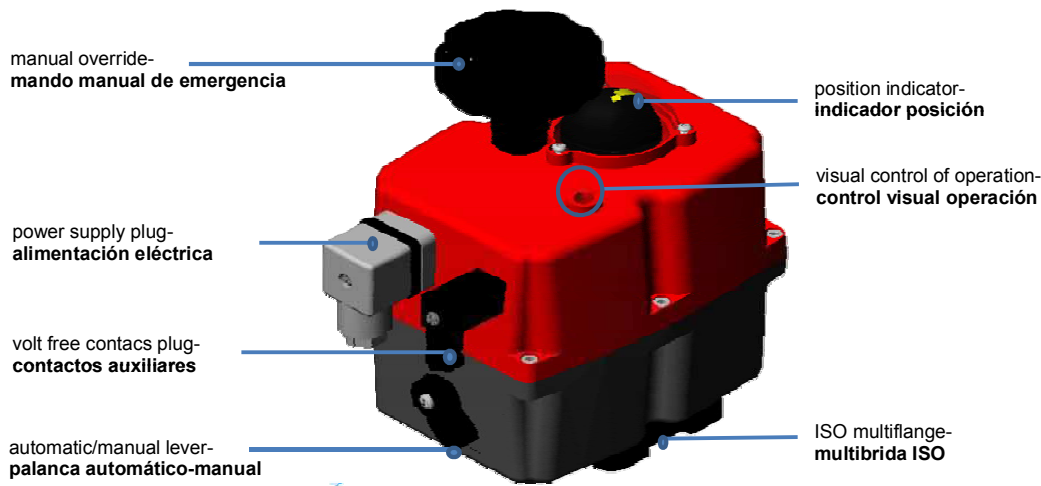

**EXTERNAL ELECTRIC WIRING / ESQUEMA EXTERNO DE CONEXIONES**

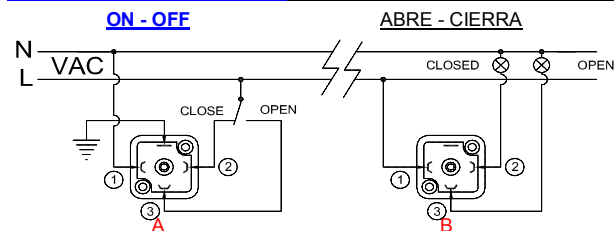

**A = Power supply plug / Alimentación eléctrica**  
**VAC 3 WIRES (Grey plug) / VAC 3 CABLES (Conector gris)**  
 PIN 1 = Neutral + PIN 2 = Phase = **Close / Cierra**  
 PIN 1 = Neutral + PIN 3 = Phase = **Open / Abre**

**B = Volt free contacts plug / Contactos auxiliares**  
 PIN 1 / PIN 2 = **Closed / Cerrado**  
 PIN 1 / PIN 3 = **Open / Abierto**

**EXTERNAL ELECTRIC WIRING / ESQUEMA EXTERNO DE CONEXIONES**

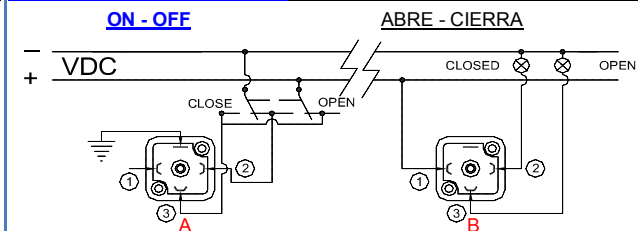

**A = Power supply plug / Alimentación eléctrica**  
**VAC 3 WIRES (Grey plug) / VAC 3 CABLES (Conector gris)**  
 PIN 1 = Neutral + PIN 2 = Phase = **Close / Cierra**  
 PIN 1 = Neutral + PIN 3 = Phase = **Open / Abre**

**B = Volt free contacts plug / Contactos auxiliares**  
 PIN 1 / PIN 2 = **Closed / Cerrado**  
 PIN 1 / PIN 3 = **Open / Abierto**

**EXTERNAL ELECTRIC WIRING / ESQUEMA EXTERNO DE CONEXIONES**

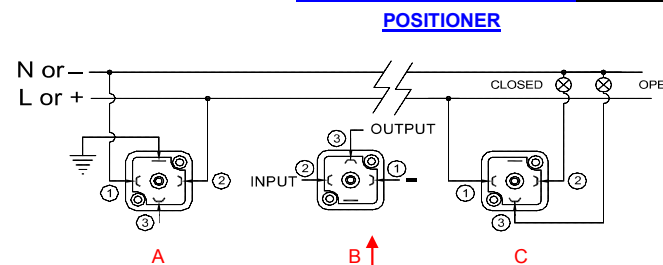

**A = Power supply plug / Alimentación eléctrica**  
**A: VAC 2 WIRES (Grey plug) / VAC 2 CABLES (Conector gris)**  
 PIN 1 = Neutral or (-) + PIN 2 or (+) = **Power supply plug / Alimentación eléctrica**

**B = Signal instrumentation / Señal de instrumentación**  
**B: Input signal : 4/20mA or 0/10V / Señal de entrada: 4/20mA or 0/10V**  
**Output signal : 4/20mA or 0/10V / Señal de salida: 4/20mA or 0/10V**  
 PIN 1 = (-)Negative + PIN 2 = (+) Positive = **Input signal / señal de entrada**  
 PIN 1 = (-)Negative + PIN 3 = (+) Positive = **Output signal / señal de salida**

**C = Volt free contacts plug / Contactos auxiliares**  
**C: PIN 1 / PIN 2 = Closed / Cerrado**  
 PIN 1 / PIN 3 = **Open**





# J3C MULTIVOLTAGE ELECTRIC ACTUATOR

## INCIDENCIAS DE FUNCIONAMIENTO ACTUATOR OPERATIONAL STATUS

Es un sistema de comunicación entre el actuador y el usuario.  
Según el tipo de luminicia nos informa de:  
The LED status Light provides visual communication between the actuator and the user.

The current operational status is shown by either solidly lit, or different flashing sequences of the LED light:

Tiempo de 200 mSeg. por cada dígito de la configuración.  
Time: 200 mSec x each digit of the configuration.

Configuración: dígito 1 = LED encendido,  
Configuration: digit 1 = LED on  
dígito 0 = LED apagado  
digit 0 = LED off

La configuración es una secuencia repetitiva que consta de cuatro columnas de cuatro dígitos.  
The configuration is a repetitive sequence of 4 columns of 4 digits.

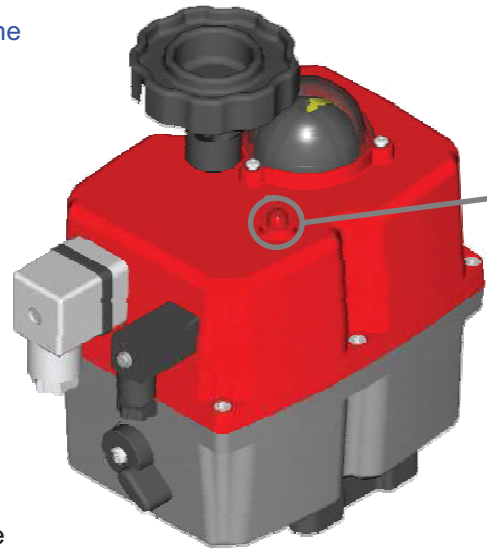

Control visual  
Operación  
Visual control  
operation

INTERMITENCIAS LED	TIEMPO	CONFIGURACIÓN
Actuador sin alimentación / Actuator without power being supplied.	100%	0000 0000 0000 0000
Actuador con alimentación / Actuator with power being supplied.	100%	1111 1111 1111 1111
Actuador limitando / Actuator with torque limiter activated.	200 mSeg.	1010 1010 1010 1010
Actuador sin alimentación. Funciona con el BSR, Max.3 min. / Actuator without power working with the BSR system. Max. 3 minutes.	200 mSeg.	1000 0000 0000 0000
Desconexión del motor por tiempo. / Actuator in MANUAL mode.	200 mSeg.	1111 0111 1000 0000
El actuador ha sido actuado manualmente y la leva ha pisado un micro. Actuator in MANUAL mode but with an internal cam operating an internal switch.	200 mSeg.	1110 1111 1111 1110
Error del posicionador. / Positioner malfunction.	200 mSeg.	1101 1011 0000 0000
Protección batería. Peligro batería baja de carga. BSR bloqueado. / Battery protection. Danger the battery needs recharging. BSR blocked.	200 mSeg.	1010 1000 0000 0000

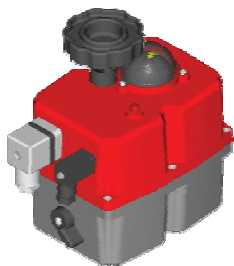

**J3C 20**

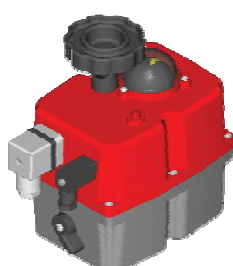

**J3C 35**

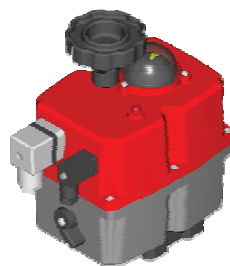

**J3C 55**

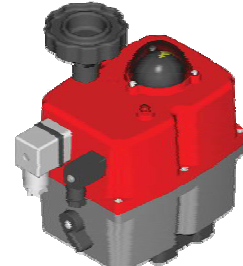

**J3C 85**

**KIT DPS J3C 20/85**

OUTSIDE BOX

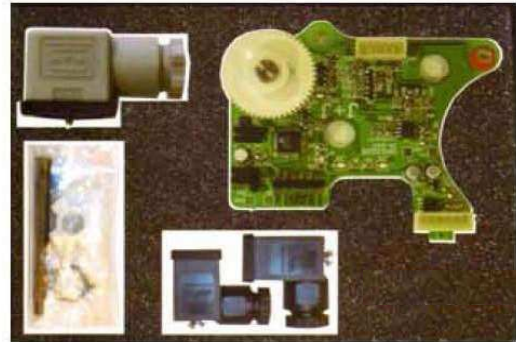

INSIDE BOX

El **DPS 2005** es un accesorio para los actuadores eléctricos J3C que los convierte en posicionador de válvulas servo controlados.

El **DPS 2005** es un módulo que incorpora un microprocesador (CPU) el cual controla digitalmente la entrada y salida de señal analógica y compara ambas con la posición del actuador a fin de establecer una relación uniforme.

Las entradas analógicas son enviadas a la CPU donde son procesadas en continua comparación con la posición del actuador lo cual permite obtener un muy alto grado de sensibilidad y una muy alta repetitividad de posición (ver características).

El posicionador **DPS 2005**, en comunicación con el sistema electrónico del actuador, provee un control integral del movimiento del actuador.

The **DPS 2005** is a device for the J3C electric actuator that turns the actuator in a servo controlled valve positioner .

The **DPS 2005** is a modulus with a microprocessor (CPU) which digitally manages the analogical input and output and compare them with the position of the actuator to establish a uniform relation.

The analogical inputs are sent to the CPU where they are processed for his continuous comparison with the position of the actuator, this allows to obtain a very high sensitivity next to a very high repetitivity of the position (see characteristics).

The **DPS 2005** in communication with the electronic system of the actuator provides an integral management of the motion of the actuator.

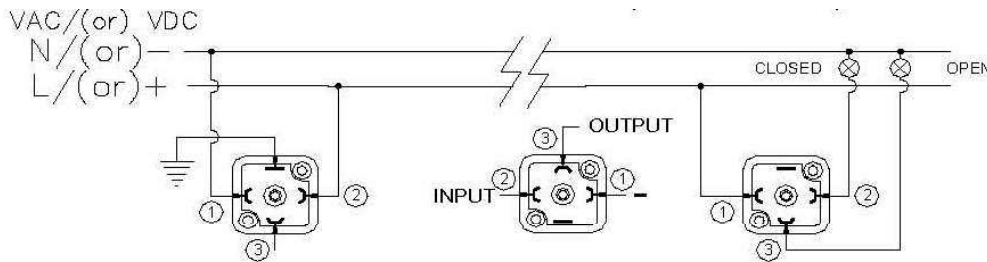
**CONEXIONES EXTERNAS / EXTERNAL ELECTRIC WIRING**

CONFIGURACIONES CONFIGURATIONS	A	B	C	D
ENTRADA / INPUT	4/20 mA	0/10 V	20/4 mA	10/0 V
SALIDA / OUTPUT				

CONFIGURACIONES (A,B,C,D), CON KIT DPS 2005 ESTANDARD  
(A,B,C,D) CONFIGURATIONS WITH STANDARD DPS 2005 KIT

Otras opciones: Other options:	E	F	G	H
ENTRADA / INPUT	0/20 mA	1/10 V	ON/OFF	ON/OFF
SALIDA / OUTPUT			4/20 mA	0/10 V

CONFIGURACIONES (E,F,G,H),CONSULTAR CON DISTRIBUIDOR  
(E,F,G,H) CONFIGURATIONS CONSULTING WITH DEALER



KIT DPS PARA MONTAR EN: DPS KIT MOUNTABLE IN:				
MODELO / MODEL	J3C-20	J3C-35	J3C-55	J3C-85
VOLTAJE / VOLTAGE	H & L	H & L	H & L	H & L
PESO (Kg) / WEIGHT (Kg)	0,525	0,525	0,525	0,525

**PIECES**

- 1 1 Cover
- 2 1 4 pins grey power DIN plug
- 3 2 4 pins small black DIN plug
- 4 1 Rubber join for the big grey DIN plug
- 5 2 Rubber join for the small black DIN plug
- 6 1 Fixing screw for the grey DIN plug
- 7 1 Fixing screw for the black DIN plug
- 8 1 Hexagonal column
- 9 1 DPS 2005 positioner PCB
- 10 1 Plastic clamp
- 11 1 DIN 7985 M4X8 screw
- 12 2 O-ring
- 13 1 Cover plug
- 14 1 Plastic clip

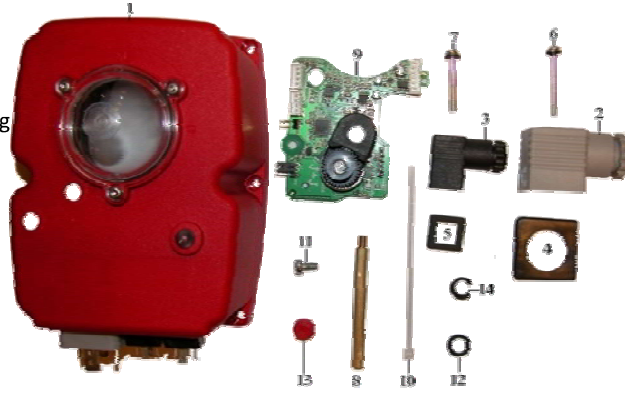

**PLEASE READ CAREFULLY BEFORE MOUNTING.**

**VERY IMPORTANT!!!! PLEASE FOLLOW THE INSTRUCTIONS STEP BY STEP**

**PREPARING THE COVER**

J3C-20, 35 & 55 model: Assembly (option A) on (hole n°2) on the cover and (option B) on (hole n°1).

J3C-85 model: Assembly (option A) on (hole n°1) on the cover and (option B) on (hole n°2).

**Option A:** Insert the O-ring (12) firmly into the recess of the cover (hole n°1 or n°2), then fully insert the cover plug (13) (Fig.2).

**Option B:** Insert the O-ring (12) firmly into the recess of the cover (hole n°1 or n°2), then fully insert the plastic clip (14) (Fig.3).

**TO CONVERT A STANDARD (ON-OFF) J3C ELECTRIC ACTUATOR INTO A MODULATING FUNCTION WITH POSITIONER, PROCEED AS FOLLOWS:**

**The unit must be disconnected from any electrical power or signal before installing.**

- 1: Unscrew the screw from the top of the hand wheel (Fig.3).
- 2: Unscrew the 6 cover screws (Fig.4).
- 3: Carefully lift the cover (Fig.5).
- 4: Carefully remove the position indicator (Fig.6).
- 5: Remove the screw from the base plate (Fig.7).
- 6: Fix the hexagonal column (8) on the base plate (Fig.8).
- 7: Mount the DPS2005 positioner PCB (9), matching the flat side of the shaft with the gear (Fig. 9, STEP 1). Press the DPS2005 positioner PCB (9) along the shaft until the DPS2005 positioner PCB connector (JP1) is plugged in the actuator PCB (JP2) (Fig. 9, STEP 2).
- 8: Fix the DPS2005 positioner PCB (9) to the hexagonal column (8) with the screw (11) (Fig.10).
- 9: Carefully insert the position indicator matching its flat sides with the flat sides of the shaft (Fig.11).
- 10: Connect the 3 pin power supply plug to the socket (1) (Fig.12) on the actuator PCB then connect the earth connector (yellow/green) cable into the socket (2) (Fig.12).
- 11: Connect the 5 pin (confirmation) plug into the socket on the vertical micro switch PCB (3) (Fig.13).
- 12: Connect the 4 pin (control signal) plug into the corresponding socket 4/20mA (5) or 0/10V (4) (Fig.14).
- 13: Fix the (blue, black and brown) cables by a plastic clamp (10) to the hexagonal column (8) (Fig.15).
- 14: Carefully mount the cover, minding the cables not to be pressed (Fig.16).
- 15: Fix the cover to the body by using the 6 screws (Fig.17).
- 16: Mount the hand wheel on the shaft and fix it by using the screw (Fig.18).

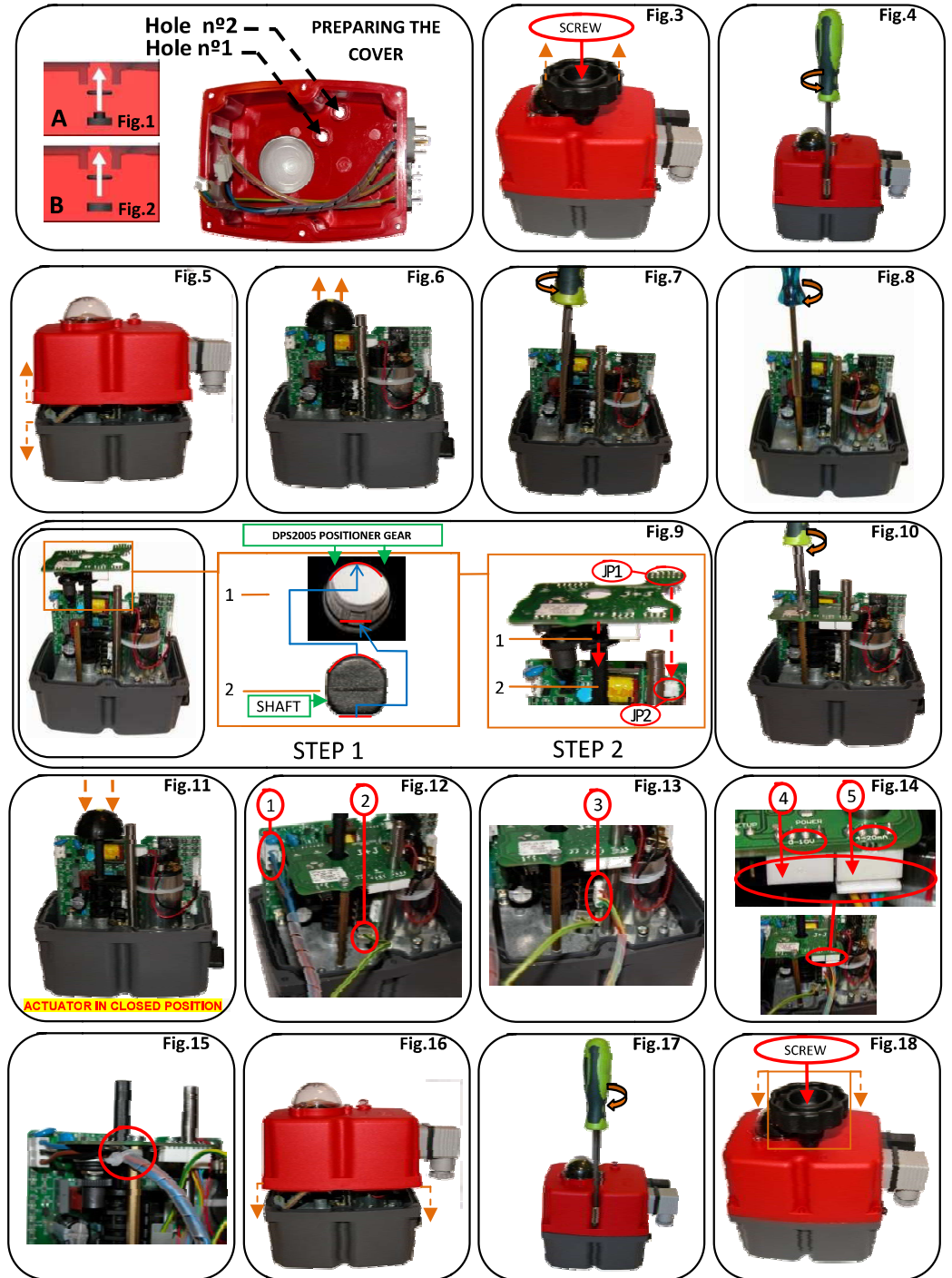

THE ACTUATOR IS READY TO WORK.



## KIT BSR J3 20/85 / J3C 20/85



OUTSIDE BOX



INSIDE BOX

El sistema de seguridad BSR es un automatismo que, incorporado a los actuadores J3 / J3C permite, en caso de interrupción de la alimentación eléctrica, situar la válvula en posición preferente predeterminada NC o NA.

En el interior del actuador se encuentra situada la tarjeta del circuito BSR más el bloque de baterías que, se encuentra en carga continua, lo que permite accionar el actuador, en caso necesario, cuando la unidad detecta un fallo de suministro eléctrico.

Hay que tener en cuenta que no se trata de un actuador "simple efecto", pero que en caso de que la válvula se encuentre en posición no preferente, el sistema BSR, mediante las baterías, accionará la válvula hasta situarla en la posición predeterminada como preferente, actuando como un actuador "simple efecto".

The BSR safety block system is an automatism that, when couple to the J3 / J3C multi voltage electric actuators, lets the valve situate in a preferable position NC or NO, when there is a power supply failure. Inside of the housing there are a BSR print circuit board and a battery pack, which is kept in continuous charge.

In case of the valve is not in the preferable position and there is a power supply cut, the BSR system returns the valve back to the preferable position by means of the batteries tension, operating as a "single acting" actuator.

### OPCIONES CONEXIONES EXTERNAS / EXTERNAL ELECTRIC WIRING OPTIONS

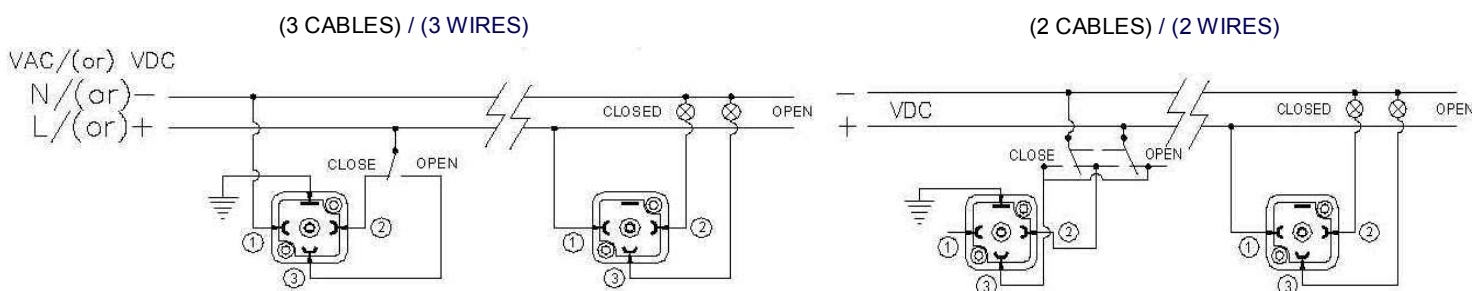

CONFIGURACIONES / CONFIGURATIONS	A	B
POSICION PREFERENTE A FALLO DE CORRIENTE PREFERRED POSITION IN CASE OF POWER CUT	(NC) NORMALMENTE CERRADA (NC) NORMALY CLOSE	(NO) NORMALMENTE ABIERTA (NO) NORMALY OPEN

### KIT BSR PARA MONTAR EN: / BSR KIT MOUNTABLE IN:

MODELO / MODEL	J3-20	J3C-20	J3C-35	J3C-55	J3C-85
VOLTAJE / VOLTAGE	H & L	H & L	H & L	H & L	H & L
PESO (Kg) / WEIGHT (Kg)	0,23	0,23	0,23	0,23	0,23



CHRYSSAFIDIS

# Ajuste de las Levas / Adjustment of the cams

LSFV001

**¡PELIGRO! TENSION ELECTRICA EN EL INTERIOR DEL ACTUADOR. MANIPULAR SOLO POR PERSONAL AUTORIZADO.**

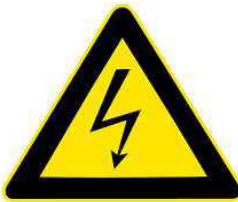

**¡WARNING! RISK OF ELECTRIC SHOCK INSIDE THE ACTUATOR. AUTHORIZED PERSONNEL ONLY.**

En condiciones normales el actuador tiene que trabajar con la tapa cerrada. Si el trabajo a efectuar en el actuador requiere la tapa abierta, el voltaje, tanto de alimentación como de control debe desconectarse primero. Los ajustes a realizar con corriente deberán llevarse a cabo con herramientas correctamente aisladas.

*Under normal conditions, the actuator may only be operated with the closed cover. If work is performed on the actuator with the removed cover, the supply and control voltage must first be disconnected. Adjustments, which need to be done in the energized state, should be carried out with special insulated tools.*

**Nota:**-Las levas están fijadas al eje mediante dos planos.

**Remark:**-The cams are fixed to the main shaft by two flats.

## ¿Cómo mover las levas?

Necesitamos una llave de plástico.

Para mover las levas solo tenemos que introducir la llave de plástico en el agujero de la leva y girarla en el sentido deseado (ver las dos opciones indicadas en las fotografías adjuntas).

### How to do it:

*Tolling: One special plastic wrench.*

*To move the cams, introduce the special plastic wrench in the hole of the cam and turn it round (see both options on the enclosed pictures).*

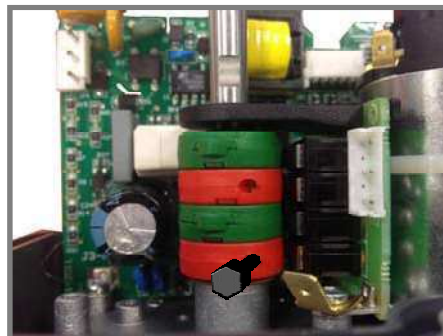
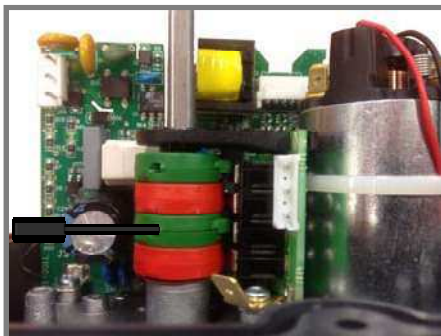
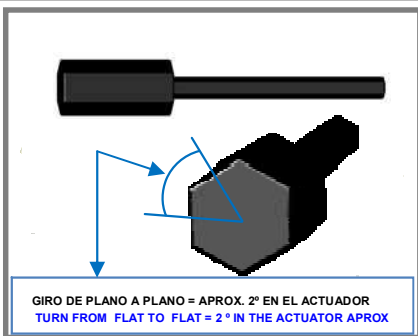

## POSICIÓN DE LAS LEVAS / POSITION OF THE CAMS

LEVA / CAM

4  
3  
2  
1

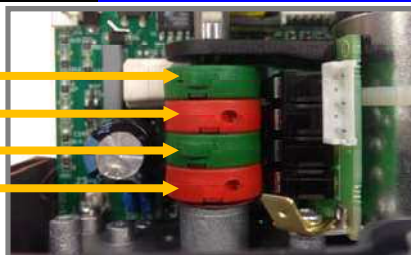

- 1) La leva 1 es para el ajuste de la posición de cerrado. / *Cam 1 is to adjust the close position.*
- 2) La leva 2 es para el ajuste de la posición de abierto. / *Cam 2 is to adjust the open position.*
- 3) La leva 3 es para el ajuste de la confirmación de cerrado. / *Cam 3 is to adjust the close position confirmation.*
- 4) La leva 4 es para el ajuste de la confirmación de abierto. / *Cam 4 is to adjust the open position confirmation.*



Para asegurar que las confirmaciones de posición funcionan, ajustar las levas de confirmación (3 Y 4) 3° antes (+/- 1°) del paro de motor.

*To ensure that the position confirmation works, adjust the confirmation cams (3 & 4) 3° (+/-1°) before the motor stop.*

- Ajustar siempre la leva 3 aproximadamente 3° antes de la posición de cerrado.

*Cam 3 should always be placed approx. 3° before the close position.*

- Ajustar siempre la leva 4 aproximadamente 3° antes de la posición de abierto.

*Cam 4 should always be placed approx. 3° before the open position.*

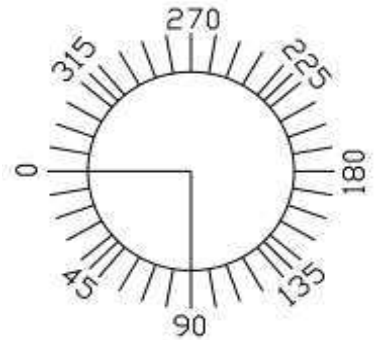

Los actuadores estándar están ajustados a 0° (cerrado) y 90° (abierto).

*The standard actuators are always adjusted at 0° (close) and 90° (open).*

### 1.- Ajustar la posición de cerrado a menos de 0° / *To adjust the close position at less than 0°.*

En este caso tendremos que girar la llave en sentido horario - levas 1 y 3.

La leva 3 tiene que pisar un poco antes de la leva 1.

*Turn the wrench to clockwise direction - cams 1 and 3.*

*The cam 3 should press the lever of the micro switch a bit earlier than the cam 1.*



### 2.- Ajustar la posición de cerrado a más de 0° / *To adjust the close position at more than 0°.*

En este caso tendremos que girar la llave en sentido anti horario - levas 1 y 3.

La leva 3 tiene que pisar un poco antes de la leva 1.

*Turn the wrench to anti-clockwise direction - cams 1 and 3.*

*The cam 3 should press the lever of the micro switch a bit earlier than the cam 1.*



### 3.- Ajustar la posición de abierto a más de 90° / *To adjust the open position to more than 90°.*

En este caso tendremos que girar la llave en sentido anti horario - levas 2 y 4.

La leva 4 tiene que pisar un poco antes que la leva 2.

*Turn the wrench to anti-clockwise direction - cams 2 and 4.*

*The cam 4 should press the lever of the micro switch a bit earlier than the cam 2.*



### 4.- Ajustar la posición de abierto a menos de 90° / *To adjust the open position to less than 90°*

En este caso tendremos que girar la llave en sentido horario, - levas 2 y 4.

La leva 4 tiene que pisar un poco antes que la leva 2.

*Turn the wrench to clockwise direction - cams 2 and 4.*

*The cam 4 must press the lever of the micro switch a bit earlier than the cam 2.*



**READ THESE INSTRUCTIONS BEFORE CONNECTING THE ACTUATOR DAMAGE CAUSED BY NON COMPLIANCE TO THESE INSTRUCTIONS IS NOT COVERED BY OUR WARRANTY.** J3 and J3C Electric actuators operate with the use of live electricity. It is recommended that only qualified electrical engineers be allowed to connect or adjust these actuators. Always ensure that the power supply is disconnected prior to removing the top cover by disconnecting the DIN power input plug. It is strongly recommended that each actuator has its own independent fuse system to protect it from the electrical influence of other electrical devices (EG: pumps).

**1.- ELECTRICAL CONNECTORS:**

**Warning:** Before connecting ensure that the voltage to be applied to the actuator is within the range shown on the identification label. The supplied electrical connectors used to connect to the actuator are DIN plugs. Ensure the diameter of cable to be used conforms to the maximum and minimum requirements of the DIN plugs to maintain water tightness.

- 1 Gasket
- 2 Terminal strip
- 3 Cable fixing screws
- 4 Housing
- 5 Grommet
- 6 Washer
- 7 Gland - nut
- 8 Fixing screw
- 9 O-ring
- 10 Gasket



FIGURA 2

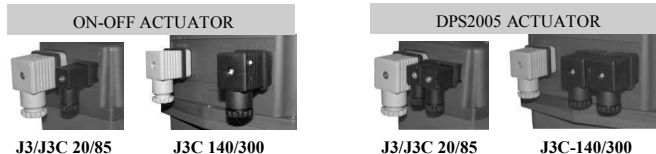

FIGURE 1

CONNECTOR	SMALL BLACK		BIG GREY		BIG BLACK	
	DIN-43650 ISO 4400 & C192		DIN-43650 ISO 4400 & C183		DIN-43650 ISO 4400 & C183	
MODEL	min Ø	máx. Ø	min Ø	máx. Ø	min Ø	máx. Ø
J3 20 to J3 85 / J3C 20 to J3C 85	5mm	6mm	8mm	10.5mm		
J3C 140 to J3C 300			8mm	10.5mm	8mm	10.5mm

**Electrical connection: All models.**

**ELECTRICAL CONNECTIONS ON/OFF ACTUATOR**

The power supply is connected to the grey DIN plug. (See Fig.3)  
 NEUTRAL PIN 1 + PHASE PIN 2 = CLOSE ACTUATOR  
 NEUTRAL PIN 1 + PHASE PIN 3 = OPEN ACTUATOR  
 EARTH/GROUND CONNECTION—FLAT PIN ON TOP

The volt free connection is made to the black DIN plug. (See fig.4)  
 COMMON PIN 1 + PIN 2 = CLOSED POSITION CONFIRMATION  
 COMMON PIN 1 + PIN 3 = OPEN POSITION CONFIRMATION

\* For other connection options please contact the vendor.

**Warning:** Ensure that the square rubber seal is in place when fixing each DIN plug to the actuator. Failure to do so could allow water ingress and damage caused by this installation error will invalidate any warranty. The DIN plugs are fixed to their respective bases on the actuator housing with a screw. Do not overtight the screw when assembling.

**Anti-condensation protection:**

The J3C actuator has an integral thermostatically controlled anti-condensation heater that is automatically activated whilst main power is applied. The heater does not require a separate supply.

**2.- LOCAL VISUAL POSITION INDICATOR:**

All J3C actuators are supplied with a local visual position indicator comprises of a black base with a yellow insert that shows both the position and direction of rotation. (see Fig.5). The open and close positions have the following logos moulded into the top cover OPEN 90 and CLOSE 0. Opening = ↺ Closing = ↻

**3.- EMERGENCY MANUAL OVERRIDE FACILITY:**

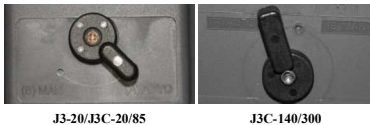

FIGURE 6

The J3C has 2 operating modes, automatic and manual, the required mode is selected by using a lever on the lower half of the actuator housing (see Fig 6). The 2 positions are marked: AUTO = Automatic operation  
 MAN = Manual operation

**Warning:** Do not remove the selector lever securing cross head screw as this will allow its internal mechanism to become loose and will cause irreparable damage to the actuator's gearbox. Removing this screw will invalidate the warranty.

When "MAN" function is selected:

- 1-The electronic system cuts the power to the motor after a few seconds.
- 2-The motor to output shaft drive is disconnected.
- 3-The desired position can be achieved by using the manual override lever or hand wheel.
- 4-There are two ways to re-activate the motor after being isolated whilst in "MAN" position:

- a) With the actuator in "MAN" function, turn the hand wheel to one of the end positions (opened or closed). If the end position switch is activated the motor stops. Now change the manual override from "MAN" to "AUTO", and the actuator is ready to operate automatically again.
- b) Change from "MAN" mode to "AUTO". Deactivate the supply voltage for a few seconds which resets the actuator and it is then change to operate automatically again.

**4-MOUNTING TO COMPONENT BEING ACTUATED (Eg: 1/4 turn valve).**

It is vital that the mounting kit used to connect the electric actuator to the component (eg: valve) is correctly manufactured and assembled. The mounting bracket's holes must be drilled to ensure that the centerline of the actuator's drive is perfectly in line with the component's drive-centerline, and that the drive coupling/ adaptor rotates around this centerline. The mounting holes of the actuator conform to ISO 5211, and the female output drive conforms to DIN 3337.

We strongly recommend that valves/components to be actuated that have ISO 5211 compliant top works are used wherever possible as it greatly assists in ensuring the concentricity of mounting the actuator to the valve.

The male square end of the drive coupling MUST NOT be longer than the maximum depth of the actuator female output drive when the assembly is bolted together.

Failure to comply with these instructions will cause uneven wear and dramatically reduce the working life of the valve and actuator.

**5-EXTERNAL LED LIGHT STATUS:**

The LED status light provides visual communication between the actuator and the user.

The current operational status of the actuator is shown by either solidly lit, or different flashing sequences of the LED light:

Time: 200 mSec. X each digit of the configuration.

Configuration: digit 1=LED on, digit 0= LED off

The configuration is a respective sequence of 4 columns of 4 digits.

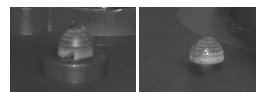

J3-20/J3C-20/85 J3C-140/300

FIGURE 7

ACTUATOR OPERATIONAL STATUS	TIME	RED LED	COLOUR LED
Actuator without power being supplied	100%	0000 0000 0000 0000	LED OFF
Actuator with power being supplied	100%	1111 1111 1111 1111	OPEN=GREEN LED / CLOSE= RED LED
Actuator, moving from ..... to ..... (flashing led)	100%	1111 1111 1111 1111	FROM OPEN TO CLOSE=RED, ORANGE/ FROM CLOSE TO OPEN=GREEN, ORANGE
Actuator w torque limit function on, moving from .... To .....(flashing led)	200 mSeg.	1010 1010 1010 1010	FROM OPEN TO CLOSE=RED, OFF / FROM CLOSE TO OPEN=GREEN, OFF.
Actuator in MANUAL mode	200 mSeg.	1111 0111 1000 0000	ORANGE, LED OFF
Actuator without power and working with the BSR system. MAX. 3 minutes	200 mSeg.	1000 0000 0000 0000	BSR NC = RED, OFF / BSR NO = GREEN, OFF
Battery protection. Danger - The battery needs recharging. BSR disabled.	200 mSeg.	1010 1000 0000 0000	ORANGE, OFF
Actuator with DPS2005	200 mSeg.	1111 1111 1111 1111	STOP=BLUE/ OPENING=BLUE, GREEN / CLOSING=BLUE, RED

**6-OPCION BSR:**

If the actuator is fitted with the BSR (Battery Spring Return) plug-in failsafe system upon electrical failure the actuator will go to the predetermined position: NO (normally opened) or NC (normally closed).

**7-KITS BSR / KIT DPS2005**

To assemble the kits, consult the manuals on [www.jibcn.com](http://www.jibcn.com)



**CHRYSSAFIDIS**